

# Waterproof switches

## INT-1169PM Series

6.2x6.2mm, Ø2.9mm Large stem, Metal cover, Radial type

**Features :** IP67 dust & water resistance

**Applications :** Home appliances or Industrial equipments  
used around water

**Specifications :**

Rating	DC 12V 50mA
Contact resistance	100mΩ Max.
Travel (mm)	0.3±0.1



**Model list :**

Model No.	Length (mm)	Operating force	Life	QTY per pack (Tape)
INT-1169PM43A	4.3	200±50gf	100,000 Cycles Min.	1K
INT-1169PM50A	5.0			
INT-1169PM70A	7.0			
INT-1169PM43B	4.3	250±70gf		
INT-1169PM50B	5.0			
INT-1169PM70B	7.0			

**Drawing :**

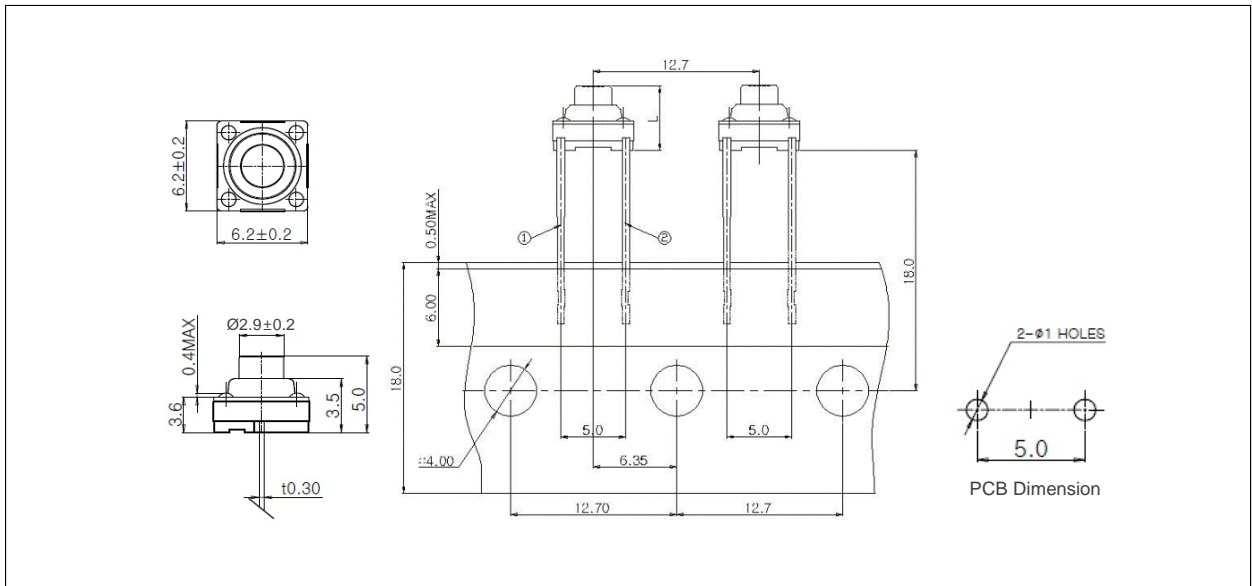

**Circuit diagram :**

